



SELECTIVE STRUCTURE

UPRIGHT FRAMES

• STRUCTURAL CHANNEL UPRIGHT FRAMES

DEPTH OF FRAME	HEIGHT OF FRAME	3" CHANNEL • 34,800 LBS CAPACITY PER FRAME*		4" CHANNEL • 52,200 LBS CAPACITY PER FRAME*	
		MODEL NO.	WEIGHT (LBS)	MODEL NO.	WEIGHT (LBS)
36"	8'	SF3-3608	70	SF4-3608	104
	10'	SF3-3610	92	SF4-3610	134
	12'	SF3-3612	124	SF4-3612	161
	14'	SF3-3614	144	SF4-3614	187
	15'	SF3-3615	152	SF4-3615	197
	16'	SF3-3616	165	SF4-3616	214
	18'	SF3-3618	184	SF4-3618	239
	20'	SF3-3620	208	SF4-3620	270
	22'	SF3-3622	224	SF4-3622	291
	24'	SF3-3624	248	SF4-3624	322
42"	8'	SF3-4208	72	SF4-4208	106
	10'	SF3-4210	95	SF4-4210	137
	12'	SF3-4212	127	SF4-4212	165
	14'	SF3-4214	148	SF4-4214	191
	15'	SF3-4215	155	SF4-4215	201
	16'	SF3-4216	169	SF4-4216	219
	18'	SF3-4218	188	SF4-4218	244
	20'	SF3-4220	213	SF4-4220	275
	22'	SF3-4222	229	SF4-4222	297
	24'	SF3-4224	254	SF4-4224	328
48"	8'	SF3-4808	74	SF4-4808	108
	10'	SF3-4810	97	SF4-4810	141
	12'	SF3-4812	130	SF4-4812	169
	14'	SF3-4814	151	SF4-4814	195
	15'	SF3-4815	159	SF4-4815	206
	16'	SF3-4816	172	SF4-4816	222
	18'	SF3-4818	193	SF4-4818	249
	20'	SF3-4820	218	SF4-4820	282
	22'	SF3-4822	234	SF4-4822	304
	24'	SF3-4824	260	SF4-4824	336

* BASED ON A MAXIMUM VERTICAL BEAM SPACING OF 60"

STRUCTURAL RACK ACCESSORIES

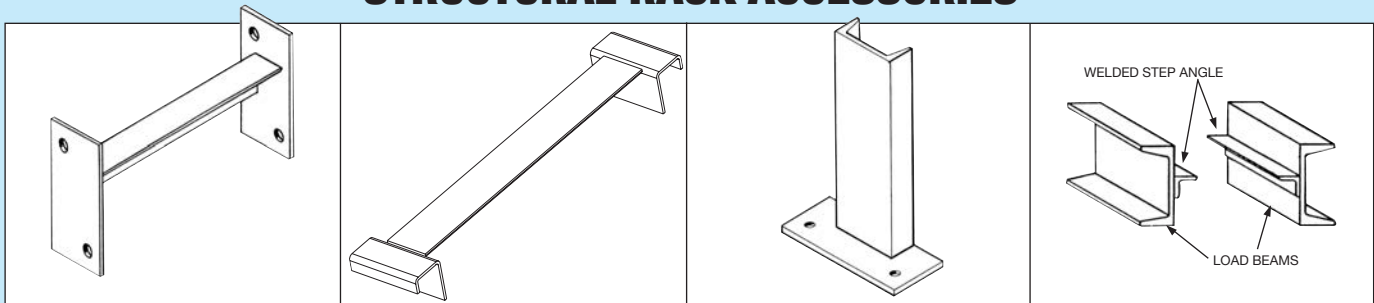

WALL TIES AND ROW SPACERS permit linking a row of racks to either the wall or a back-to-back row of racks. Maintain spacing while providing additional stability to the system.

PALLET SUPPORTS prevent undersized loads from falling through the beams, support weak pallets or serve as a deck support. Both drop-in and bolted models are available.

STRUCTURAL POST PROTECTORS provide extra protection from forklift abuse in the lower frame areas.

LOAD BEAMS WITH STEP ANGLE permit a custom deck to be placed in the pallet rack system for added versatility. Step angle is factory welded to the inside of the load beam at custom heights to meet individual requirements.

Other popular accessories such as fork clearance bars, skid channels, steel decks and drum cradles are available.
Contact your MECO OMAHA representative.